

THERMOMARK™ 5150 FLUSH INSULATED OVERHEAD DOORS

PROJECT:

CONTRACTOR:

Pittsburgh Material Handling
PH: 888-557-1515 FAX: 888-564-2525

DOOR DISTRIBUTOR:

DRAWING No.:

SHEET No.:

OF

DRAWN BY:

DATE:

FRAMING NOTE: WAYNE-DALTON CORP. DESIGN ENGINEERS EACH COMMERCIAL SECTIONAL OVERHEAD GARAGE DOOR FOR INDIVIDUAL APPLICATIONS BASED ON PRODUCT & OPTIONS REQUIRED. ONE, TWO OR FOUR SPRING TORSION ASSEMBLIES ARE TYPICALLY SUPPLIED AS STANDARD. DUAL TORSION SHAFT ASSEMBLIES ARE SUPPLIED WHEN REQUIRED. WHEN IT IS TIME TO PREPARE THE OPENING(S) FOR INSTALLATION OF A WAYNE-DALTON PRODUCT, CONTACT OUR CUSTOMER SERVICE REPRESENTATIVES FOR MOUNTING PAD LOCATIONS.

STANDARD FEATURES

1. GRADUATED HOT-DIPPED GALVANIZED STEEL END HINGES (14 GAUGE MINIMUM).
2. ADJUSTABLE HOT-DIPPED GALVANIZED STEEL TOP BRACKETS.
3. HOT-DIPPED GALVANIZED STEEL BOTTOM BRACKETS WITH CABLE ATTACHMENT.
4. (4) 1/4"-20 TEK SCREWS PER HINGE.
5. (4) 1/4"-20 TEK SCREWS PER TOP BRACKET.
6. FLUSH EXTERIOR-HOT-DIPPED GALVANIZED STEEL WITH EMBOSSED WOODGRAIN PATTERN. PRE-PAINTED PRIOR TO ROLL-FORMING (.2 MIL PRIMER & .7 MIL POLYESTER FINISH COAT).
 WHITE BROWN
7. FLUSH INTERIOR-HOT-DIPPED GALVANIZED STEEL WITH EMBOSSED WOODGRAIN PATTERN. SURFACE IS PRE-PAINTED PRIOR TO ROLL-FORMING (.6 MIL POLYESTER WHITE FINISH COAT).
8. 20 GA. HOT-DIPPED GALVANIZED STEEL RETAINER WITH PVC "BULB-SHAPED" BOTTOM ASTRAGAL.
9. TONGUE & GROOVE JOINT WITH JOINT SEAL.
10. CFC FREE POLYURETHANE CORE SANDWICH-TYPE CONSTRUCTION INCLUDES THERMAL BREAKS EACH SECTION. ASHRAE CALCULATED "R"-VALUE = 10.96.
11. 20 GA. BUILT-IN REINFORCEMENT PLATES FOR HARDWARE ATTACHMENT.
12. HOT-DIPPED GALVANIZED STEEL WRAP-AROUND END CAPS:
18 GA.-SINGLE END HARDWARE (UP TO 14'-2" WIDE).
16 GA.-DOUBLE END HARDWARE (OVER 14'-2" WIDE).
13. EXTERNALLY ATTACHED STRUTS AS REQUIRED.

FREQUENTLY SELECTED OPTIONS

14. PVC TOP SECTION HEAD SEAL
 15. 24x6 LITES WITH HIGH-IMPACT POLYMER FRAME:
 1/2" DOUBLE INSULATED SSB THERMOLITE
 1/4" ACRYLIC (PLEXIGLASS)
 1/4" POLYCARBONATE (LEXAN)
 1/4" POLISHED WIRE GLASS
 1/2" DOUBLE INSULATED TEMPERED THERMOLITE
 24x12 BUBBLE LITE (NOT SHOWN)
 COLONIAL LITES (NOT SHOWN)
 1/8" SSB GLASS
 1/2" DOUBLE INSULATED SSB
- _____ No. SECTIONS GLAZED
- _____ No. LITES PER SECTION
16. ALUMINUM FULL VIEW SECTION: WHITE BROWN
 1/8" DSB
 1/8" ACRYLIC (PLEXIGLASS)
 1/8" TEMPERED GLASS
 1/8" POLYCARBONATE (LEXAN)
 1/4" TEMPERED PLATE GLASS
 1/4" POLISHED WIRE GLASS
 1/4" PLATE GLASS
 1/4" ACRYLIC (PLEXIGLASS)
 1/4" POLYCARBONATE (LEXAN)
 1/2" DOUBLE INSULATED (SSB GLASS)
 1/2" DOUBLE INSULATED (TEMPERED GLASS)
- _____ No. FULL VIEW SECTIONS
17. 3" EXHAUST PORT (CENTERED BOTTOM SECTION).
 18. OMIT LOCKING (INSIDE SIDE LOCK STANDARD)
 STANDARD SIZE RIM CYLINDER SHORT LOCK BAR (NOT AVAILABLE IN ALUMINUM FULL VIEW).
 19. CABLE FAILURE DEVICE.

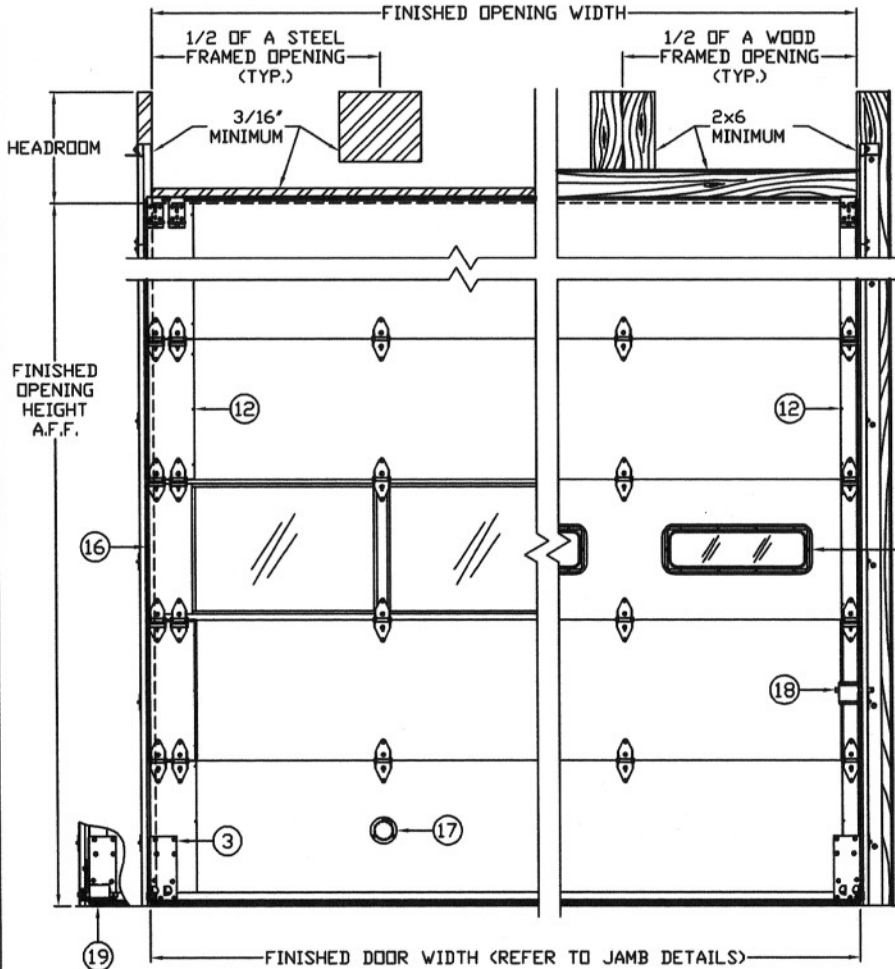

INTERIOR ELEVATION

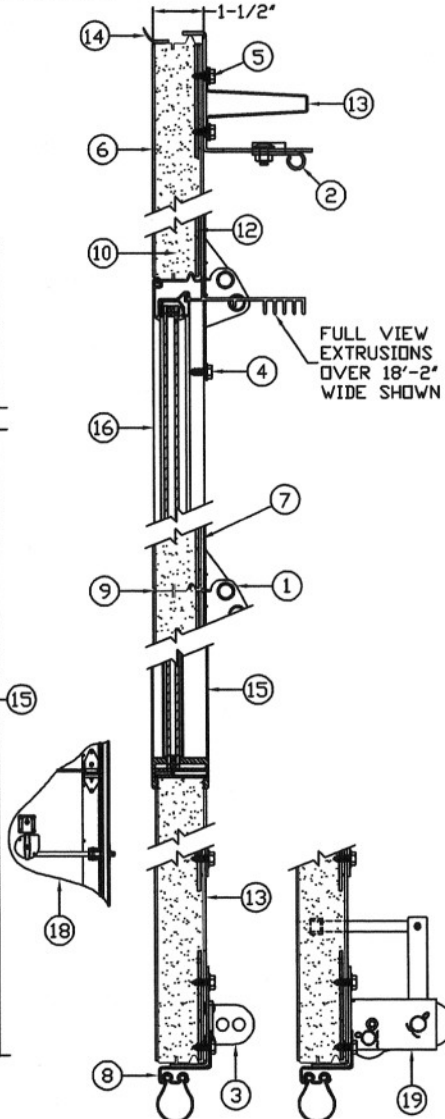

CONSTRUCTION